

## FLOAT LEVEL REGULATOR

For automatic regulation with several devices

ATEX Marking code - CE 0081  II 1 GD Ex ia IIC T6 Ga Ex ta IIIC T70°C Da IP68



### USE

VR – Emptying / Filling

### SIZE

Height: 200 mm – Diameter: 92 mm

### DIFFERENTIAL ANGLE

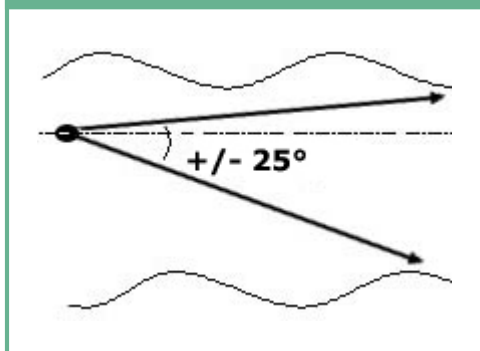

### WIRING

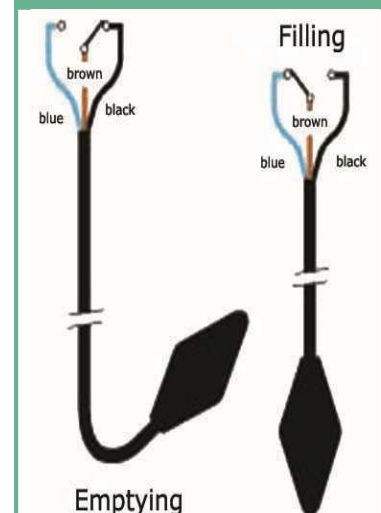

Please, refer to the connection diagram enclosed to each float delivered.

### APPLIANCES

Same applications as the SOBA HR HY model. However, it is especially designed for working in explosive gas areas : solvents, hydrocarbons, alcohols, chemical and pharmaceutical products (please, refer to the SOBA HR HY technical sheet)

### TECHNICAL CHARACTERISTICS

|                                      |   |
|--------------------------------------|---|
| Operation mode                       | Omnidirectional                                       |
| Allowed fluid density                | 0,80 a 1,10   |
| Maximum pressure                     | 4 bars  |
| Maximum temperature                  | Ta: from -20°C to +70°C / idem                        |
| Protection index                     | IP 68   |
| Electric characteristics             | 24 VAC/VDC – 10 mA or 12 VAC/VDC – 100 mA             |
| Obligatory connection                | With intrinsic safety relay                           |
| Microswitch                          | Gold plated reverser contacts                         |
| Biconical shell (2)                  | Copolymer polypropylene + HR HY (hypalon)             |
| Cable                                | HR HY (hypalon) H07RN-F                               |
| Cable type                           | 3 conductors 1 mm <sup>2</sup>                        |
| Float weight without cable           | 300 g   |
| Cable weight                         | HR HY 110 g/m   |
| Adjustable ballast on cable (series) | Loaded resin 250 g                                    |
| Standard cable length (series)       | 5, 10, 15, 20, 25 and 30 m (other lengths on request) |

## FLOAT LEVEL REGULATOR

For automatic regulation with several devices

ATEX Marking code - CE 0081  II 1 GD Ex ia IIC T6 Ga Ex ta IIIC T70°C Da IP68



### ATEX CERTIFICATION – WHAT YOU SHOULD KNOW

It is important to know that the level regulation devices certified ATEX are compulsory in the main pumping stations, granular silos and some pulverulent materials storage facilities. It is also important to know that only the user can define, before the installation, if it deals or not with a pumping station or a silo with explosive risks. The atmosphere is classified 0, 1, 2 for gas and 20, 21, 22 for dusts. So, it is highly recommended taking no risks in this situation as it can trigger disastrous consequences.

PROTECTION- The SOBA Ex are designed and certified for use in hazardous areas classified 0, 1, 2 (gas) and 20, 21, 22 (dusts). They are conform to the following standards:

- EN 60079-0 (2012)
- EN 60079-11 (2012)
- EN 60079-31 (2009)
- Particularly explosive areas of gas (IIC group) and dusts (IIIC group).

Certified LCIE 00 ATEX 6003 X according to the Directive 94/9/CE

CONNECTION - **BE CAREFUL !** The non-respect of the following instructions can have serious consequences. These floats must only be connected to an intrinsically safe associated apparatus certified type. Such apparatus must be compatible with the intrinsic security instructions and must not exceed the floats electric characteristics values mentioned on the technical sheet n°1. The non respect of that would trigger the destruction of the microswitches gold plated contacts. All connections must be performed according to the Low Voltage Directive and Intrinsic Safety instructions.

$L_I \leq 2\mu H$  and  $C_I \leq 203 pF$  with 2 m cable length (*Lineic inductance: 0.36 mH (Millihenry)/km divisible by 1000 for a value in metre*).  $U_o \leq 30V$ ,  $I_o \leq 100 mA$ ,  $P_o \leq 0.75 W$  (associated intrinsically safe)

**IMPORTANT**- A use which is not specified by the constructor or an non competent authority intervention can damage the working of these devices and trigger serious consequences. The manufacturer denies all responsibility if the user does not respect the rules in relation with the protections against sanitary, fire and explosion risks.

PRODUCT FOLLOW-UP - The number of the series and the year of production appear on each device delivered.

AT YOUR DISPOSAL - LCIE 00 ATEX 6003X. Information about the intrinsic safety relays. Connection diagrams...